



**MATERIAL HANDLING**

**optibelt ATC-SYSTEM**





**NEW**  
IN OUR  
ASSORTMENT

# optibelt **ALPHA ATC**

## **POLYURETHANE TIMING BELTS WITH FLEXIBLE CLEAT SYSTEM**

optibelt ALPHA ATC makes complex drive solutions possible in all areas of mechanical engineering under the most difficult conditions and extreme operational demands.

- **PATENTED DRIVE SYSTEM SOLUTION**
- **SIMPLE AND QUICK ASSEMBLY**
- **FLEXIBLE PROFILE ASSEMBLY ON SITE**



# optibelt ATC-SYSTEM

## – FOR FLEXIBLE TRANSPORT APPLICATIONS

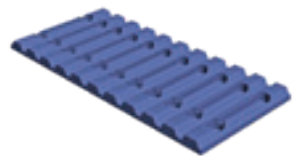
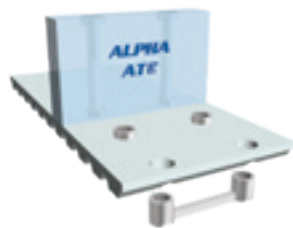
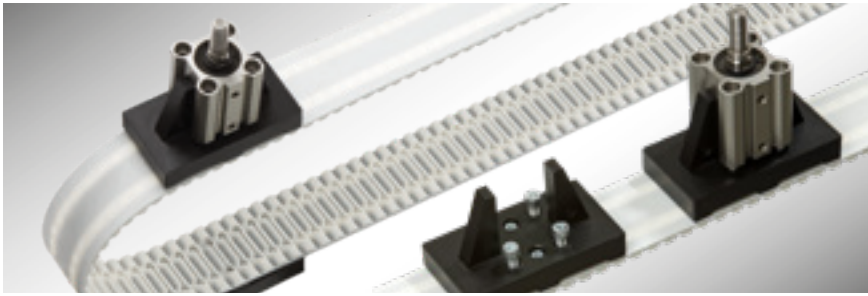

ATC profile with recesses for ATC-IN inserts in each tooth

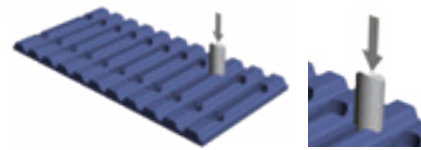

Punching of a through-hole with ATC-PT punching tool

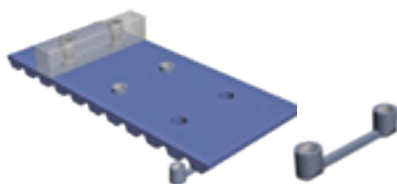

ATC profile with punched holes for ATC-IN inserts and installation of a screw-on cleat

The user of the **ATC-System** can fasten screw-on cleats quickly and easily to a freely selectable tooth, on the spot. The connection can be fastened and detached directly by the user. As a result, varying forms of transported goods can be conveyed on the same drive and base belt using different screw-on cleats. With detachable cleat fastenings, the costs for stock-keeping of wear and spare parts can be reduced.

**ATC** inserts also make it possible to screw parts on directly, such as highly precise metal workpiece carriers, without using welded-on, specially manufactured cleats with inserts. Furthermore, screw-on cleats can transmit higher forces in comparison to permanently connected cleats. In addition, a smaller minimum pulley diameter can be chosen for the same fastening strength. Screw-on cleats for the **ATC-System** are available on request.

With the **ATC-System**, an **ATC-IN** insert for screwing on the cleat is laid into the prepared recess in the tooth. In the **optibelt ALPHA V** timing belt, these recesses are consistently available in all teeth in profiles **ATC10** and **ATC20**.

### PROFILE ATC10

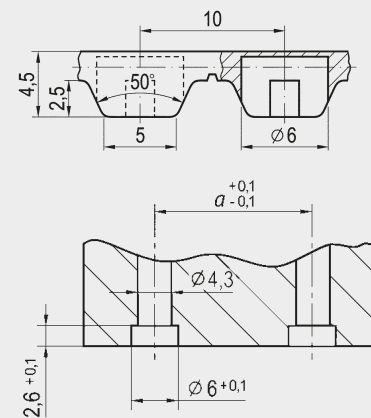

Connecting dimensions of a screw-on cleat with a centre distance "a" depending on the **ATC** insert

Cleats for belt widths 50 mm and 100 mm, which were designed for a fastening system available on the market using individual inserts, are compatible with the **ATC-System** for profile **ATC10**. Existing cleats can be used without the need for any additional measures.

### ACCESSORIES



- ① **optibelt ATC-PT** punching tool
- ② **optibelt ATC-IN** insert  
Material: stainless steel
- ③ Screw-on cleat

# optibelt ATC-SYSTEM

## ASSIGNMENT AND PROPERTIES

ATC belt profile	ATC standard belt width [mm]	ATC insert	Number of ATC inserts/ blind holes or threads	Centre distance of blind holes or threads [mm]	Thread	Minimum length ALPHA V [mm]
ATC10	25	ATC-IN M4-14RF	1/2	14	M4	850
	32		1/2			850
	75		2/4			1050
ATC10	50	ATC-IN M4-25RF	1/2	25	M4	850
	100		2/4			1050
	150		3/6			1150
ATC20	50	ATC-IN M5-25RF	1/2	25	M5	1060
	100		2/4			1160
	150		3/6			1160

The belt top surface is smooth and does not initially contain any holes. Before the **ATC** insert is inserted, the two pre-formed blind holes in the recess of the selected tooth must be punched out with the **optibelt ATC-PT** punching tool to produce through-holes. To facilitate punching or perforating, the **optibelt ALPHA V** timing belt with **ATC10** and **ATC20** profiles does not have tension cords in the area of the blind holes.

The **optibelt ALPHA ATC** with profile **ATC10** in the standard design is also available with polyamide fabric on the tooth side (PAZ). The **ATC10** profile is also available with stainless-steel tension cords, for applications in the food and pharmaceutical industry.

The **ATC** stainless steel (RF) insert consists of two sleeves which are interconnected by a stable web. On the tooth side, the **ATC** insert is designed in such a way that it lies completely in the tooth contour and does not touch the tooth system of the timing belt pulley.

Profile	D*
ATC10	6
ATC20	7.5

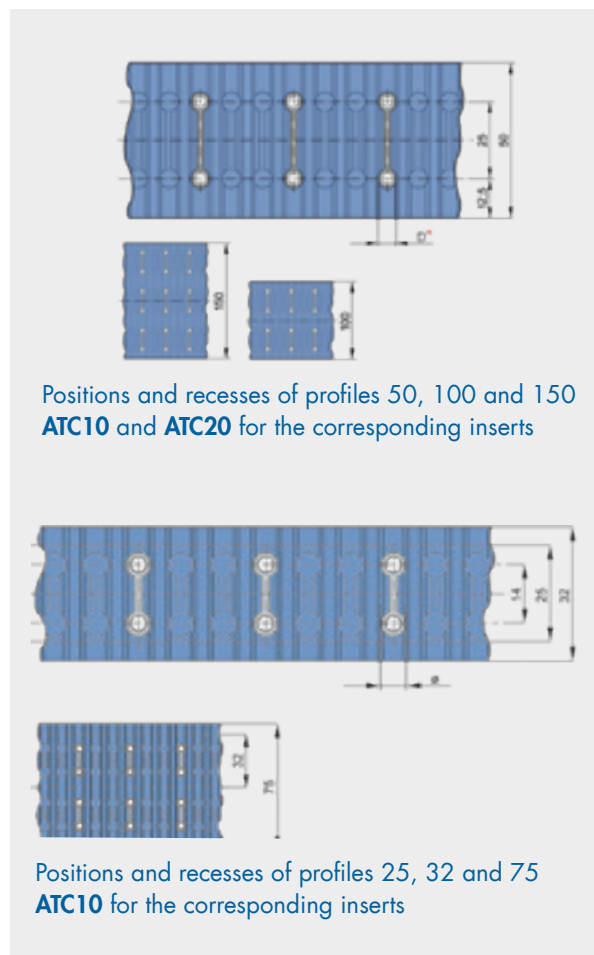

# optibelt **ATC-IN** INSERTS

## ASSIGNMENT TO BELT PROFILES AND PROPERTIES

The two sleeves of the **ATC-IN** inserts have a continuous internal thread for fixing to the screw-on profiles. The sleeves, which protrude beyond the belt top surface, ensure that the profiles are centred.

The centring ensured by the two sleeves also provides anti-twist protection for the screw-on profiles.

The connecting dimensions of the screw-on profiles can be found in the accompanying table and drawing. The centre distance should be selected as for the **ATC-IN** insert.

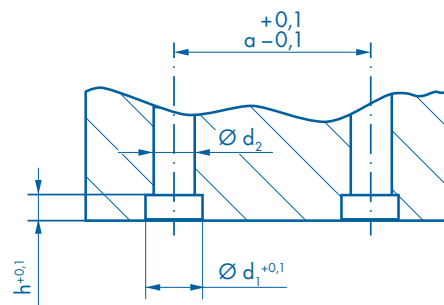

	$h^{+0,1}$	$d_1^{+0,1}$	$d_2$
ATC10	2.6	6	4.3
ATC20	3.1	7.5	5.3

The thrust, tensile or bending loads acting via one or both sleeves on the installed screw-on cleat are absorbed by the whole **ATC-IN** insert. Due to the introduction of force into the base belt over a large area, very high stability and functional reliability of the screw-on cleat fastening can be achieved with the **ATC-System**.

With an acting load on the screw-on cleat with a width of 50 mm and a force applied at a height of 15 mm, the following average breaking loads for the connection can be assumed for an **ATC-IN-M4-25** insert:

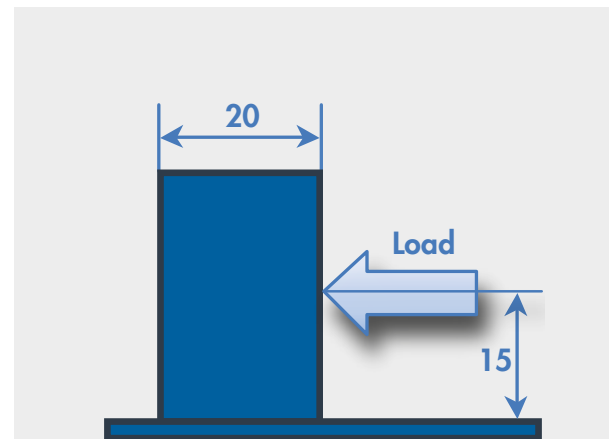

**Screw-on cleat with dimensions:  
50 x 30 x 20 mm (w x h x d)**

The values relate to a cleat with a load applied at a height of 15 mm. The values will vary for differently applied loads.

ATC-IN insert	Average breaking load of an ATC connection
ATC-IN M4-25 RF	5200 N

# optibelt **ATC-IN** INSERTS

## ASSIGNMENT TO BELT PROFILES AND PROPERTIES

Belt width [mm]	Belt profile	ATC insert	Number of inserts	Centre distance between threads [mm]	Thread	Minimum length for smallest belt width [mm] <sup>1</sup>	Note
25–150	AT10	ATC-IN M4–14	freely selectable depending on belt width	14 or free between inserts	M4	700	ALPHA SPECIAL
40–150	AT10	ATC-IN M4–25	freely selectable depending on belt width	25 or free between inserts	M4	700	ALPHA SPECIAL
45–150	AT20	ATC-IN M5–25	freely selectable depending on belt width	25 or free between inserts	M5	900	ALPHA SPECIAL

<sup>1</sup> Minimum length for larger widths on request; observe minimum lengths of base belts

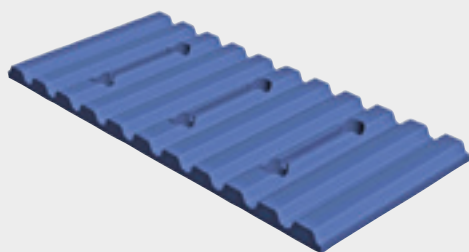

**optibelt ALPHA SPECIAL** with AT profile with subsequently produced recesses including through-holes

For even smaller widths of **optibelt ALPHA SPECIAL** of 25 mm, we recommend using the second standard insert **optibelt ATC-IN M4–14**. This insert corresponds to the connecting dimensions of an **optibelt ATC-IN M4–25** insert, but with a centre distance reduced from 25 mm to 14 mm.



**optibelt ATC-IN** inserts are available in batch sizes of 10/25/100 pieces.

**Optibelt GmbH**

Corveyer Allee 15  
37671 Hörter  
GERMANY

T +49 5271 621  
F +49 5271 976200  
E [info@optibelt.com](mailto:info@optibelt.com)



[www.optibelt.com](http://www.optibelt.com)